

# Installation, Operation and Maintenance Instructions



## **SOLIDS FROM LIQUIDS CENTRIFUGE HP20 SINGLE, HP40 DOUBLE**

**ERIEZ** HEADQUARTERS: 2200 ASBURY ROAD, ERIE, PA 16506-1402 U.S.A.  
*GLOBAL LEADER IN SEPARATION TECHNOLOGIES*

---

# Introduction

This manual details the proper steps for installing, operating and maintaining the Eriez Centrifuge.

Careful attention to these requirements will assure the most efficient and dependable performance of this equipment.

If there are any questions or comments about the manual, please call Eriez at 814-835-6000 for centrifuge assistance.

---

 **CAUTION**

**Safety labels must be affixed to this product.  
Should the safety label(s) be damaged, dislodged  
or removed, contact Eriez for replacement.**

---

# Table of Contents

## ERIEZ CENTRIFUGE, MODELS HP20 SINGLE & HP40 DOUBLE

GENERAL INFORMATION.....	5
GENERAL HEALTH, SAFETY AND WARNING NOTICES .....	5 - 6
GENERAL RISK AND HAZARD ASSESSMENT .....	7 - 8
PRINCIPLE OF OPERATION, GENERAL DESCRIPTION .....	8
INSTALLATION .....	9 - 11
OPERATION .....	12
MAINTENANCE .....	13 - 15
SPARE PARTS.....	15
TROUBLESHOOTING .....	16
OUTLINE HP20 CENTRIFUGE .....	17
OUTLINE HP40 CENTRIFUGE.....	18
ELECTRICAL SCHEMATIC HP20 SINGLE CENTRIFUGE.....	19
ELECTRICAL SCHEMATIC HP40 DOUBLE CENTRIFUGE.....	20
HP20 CENTRIFUGE SPARE PARTS.....	21
HP40 CENTRIFUGE SPARE PARTS.....	22
CENTRIFUGE ELECTRICAL DISCONNECT.....	23
HP20 STAND ALONE CENTRIFUGE WITH INLET PLUMBING .....	24
HP40 STAND ALONE CENTRIFUGE WITH INLET PLUMBING .....	25



# General Information

## Introduction

The Eriez Centrifuge units are a Solids/Liquid Separation unit (Clarifier).

The unit provides; efficient filtration typically to 10 micron nominal, proven technology, suitable for a wide range of fluids and viscosities, non-consumable and is offered in a variety of configurations.

## Responsibility

Eriez will not be responsible for any malfunction of equipment as a result of the customer's failure to follow the instructions detailed in this manual. If you have any queries regarding the information or instructions given in this manual, do not hesitate to contact your Eriez representative.

## Using This Manual

This manual is intended solely for Eriez "Solids from Liquids Centrifuges."

This Manual consists of numerous chapters. If you are reading this manual for the first time, it is recommended that you read each chapter in order.

- General Information
- General Health and Safety
- Risk and Hazard Assessment
- Equipment Description
- Installation
- Operation
- Maintenance
- Spare Parts
- Troubleshooting

# General Health, Safety and Warning Notices

## WARNING

This chapter contains important safety related information. It is strongly recommended that you familiarise yourself with the information in this chapter before proceeding through this user manual. Failure to do so could lead to the risk of injury or death.

## Safety Advice

### WARNING

The safety advice section on the next page must be read before any work is attempted.

# Health and Safety Factors

There are several factors which have a bearing on the Health and Safety aspects concerned with this installation. These are as follows:

Weight:	The weight of the components of the installation
Noise Levels (at workstation):	Noise levels may exceed the levels at which hearing protection is required.
Voltages:	Lethal voltages are used in this installation.
Moving Machinery:	Moving components are present in this installation.
Heat:	High temperatures are generated during the operation of this installation.
Radiated Extraneous Electric Fields:	Extraneous electric fields may be radiated by electromagnetic devices if used in this installation.

## Safety

Motors, magnets or coils employed in this installation operate using potentially lethal electrical power and therefore should be treated with the utmost caution and respect. To avoid the possibility of personal injury or even death, the following points must be closely observed:

### WARNING

Never allow the machine to be operated by untrained personnel.

Never allow the operation, maintenance or rectification of the installation or its components to be carried out by personnel other than those who have been suitably trained and declared competent to carry out such tasks.

Never put the installation back into use following maintenance or rectification until it has been checked by suitably trained and qualified staff and declared as safe to do so.

Never operate the installation with any guards, panels or doors removed or open. Always ensure that they are in a serviceable condition, correctly secured and locked prior to switching on the machine.

Never modify the installation or its components so that they will operate with any of the safety features disabled i.e. short circuited, linked out or by-passed in any way.



## Lifting Aids

Personnel are to be aware of the weight of the installation and its components and are strongly advised to use trained personnel and mechanical lifting aids wherever possible. To avoid the risk of injury, personnel are to ensure that prior to attempting an unaided lift the weight involved does not exceed the recommended limits laid down under the Health and Safety Act, or any other legislation, and that suitable protective clothing is worn.

## Noise

Eriez has taken all reasonably practical measures to reduce noise to levels which are safe and without risk to the health of a normally fit operator. It is, however, possible that a noise level in excess of 80dBA may occur in the vicinity of the installation. Customers should make sound level measurements of the installation when installed and operating under normal load conditions within the rating of the equipment. This will take into account the installation and its environment and enable the appropriate level of action to be determined in accordance with the following guidelines:

- **Below 80dBA:** No action required.
- **Above 80dBA:** Consideration of improvements to the machine environment to reduce the noise level. At this level and above, consideration should be given to the provision of visual warning signs and the provision of hearing protection for the operator.

## Lethal Voltages

Lethal voltages are employed in this installation and warning notices are displayed

## Moving Machinery

Linear moving components are employed during the operation of this installation. The fitting of guards etc. to prevent access by operators is strongly recommended. Any additional guarding required due to additional hazards presented by the customer's environment/machinery is the responsibility of the customer.

## Heat

During the operation heat is induced into the installation and its components, therefore direct contact with the assembly etc. during or immediately following operation of the installation should be avoided without handling equipment and protective clothing.

## Electromagnetic Compatibility

This equipment has been so constructed that it does not cause excessive electromagnetic interference and is not unduly affected by electromagnetic interference.

This equipment should not be operated with any doors or panels open as this may reduce the effectiveness of the electromagnetic radiation and immunity screening.

Regular maintenance procedures as outlined elsewhere in this manual should be observed.

## Warnings and Safety Instructions

The need to observe the warnings and safety instructions at all times cannot be emphasised too strongly and, in particular, the potentially lethal consequences of working on an electrical component with the mains supply switched on, and the risk of burns due to the temperature of treated wire, operating electrical equipment and cooling systems.

## Guards and Barriers

The equipment supplied by Eriez is fitted with guarding as required by health and safety to meet with the requirements of the Machinery Directive 2006/42/EC.

It is the customer's responsibility to install any additional guards and barriers as required to prevent unauthorized access to the installation this machine will be working with and protect the operators from any hazards present once the installation is complete.

## Maintenance Staff

Only the maintenance engineer or a suitably qualified member of his staff should attempt to maintain or rectify the installation or its components. It is the responsibility of the maintenance engineer to ensure that following any maintenance or rectification tasks, all guards, safety interlocks and earthing circuits are correctly fitted, fully functional and the installation is in a safe condition to be operated.

---

**!** Eriez cannot accept any responsibility for accidents or damage caused by over-riding the safety interlock circuits or non-compliance with any warnings issued in this user manual.

---

# General Risk and Hazard Assessment

## WARNING

**DO NOT install, commission or operate this machinery until this manual has been carefully read.**

## Guards and Barriers

The equipment supplied by Eriez is intended to be incorporated into an existing facility at the end users site. Due to hot surfaces and moving machinery being exposed during the process it is the customer's responsibility to install guards and barriers as required to prevent unauthorized access to the installation and protect the operators from any hazards present once the installation is complete.

## Statement of Designed Method of Operation

The installation was designed following a requirement from the customer on the method of operation of this installation. It is the responsibility of the customer to take responsibility for any associated hazards as a result of this requirement.

It is the responsibility of Eriez to make the customer aware of any hazards that may exist within the parameters specified.

The installation is designed to extract solids from coolant and provide clean coolant ready for use that is stored in a clean coolant tank. The process is continuous.

## Risk and Hazard Assessment Parameters

The parameters for risk and hazard evaluation for the installation during normal working operation have been taken from the following instructions: Machinery Directive Risk Assessment 2006/42/EC, and Atex Directive 94/9/EC.

It is the full responsibility of the customer to ensure that the surrounding environment is made safe for the operators, following all the recognized safety standards.



## Residual Hazard Identification

This manual is only concerned with any hazards that may concern the operators within the parameters specified above.

Where possible protection has already been provided (i.e. selection of certified components) and so therefore these are no longer considered a hazard.

## Keywords and Symbols

Please pay special attention to sections of text with these allocated symbols:

	General Symbol for: Danger! Caution! Attention! Important!
	Risk of electrical shock hazard
	Risk of body crush hazard
	Injury by rotating blades hazard
	Lifting hazard
	Body crush/tip over hazard

## Motors/Pumps

### WARNING

**This may be controlled by local or by remote means and could start up without warning!**

## Warnings

Warning Plates, Caution Plates and Safety labels on the separator must not be removed or painted over. It is important these warnings and cautions are legible and complied with.

## Corrosive Materials

Equipment parts used are appropriate to the intended mechanical and thermal stresses and capable of withstanding attack by existing or foreseeable aggressive substances.

The equipment is designed in accordance with EN ISO 12100 and good engineering practice. It's the User's responsibility, to ensure chemical compatibility with the materials used.

If the equipment is likely to come into contact with aggressive substances, then it is the responsibility of the user to take suitable precautions that prevent it from being adversely affected, thus ensuring that the type of protection is not compromised. Aggressive substances - e.g. acidic liquids or gases that may attack metals or solvents that may affect polymeric materials.

Suitable precautions - e.g. regular checks as part of routine inspections or establishing from the material's data sheet that it is resistant to specific chemicals.

## Principle of Operation, General Description

### General Description

The Model HP-20-02 Coolant Centrifuge has a single rotor and a swivel elbow type inlet for the dirty coolant entry. The speed of the direct drive motor is 3420 RPM for a sustained G-force of 1600. This allows the centrifuge to be used for applications such as EDM that are normally considered to be out of reach for a low speed centrifuge. Flow rate is 18-20 GPM (68-76 LPM) with water. Refer to "specifications" for coolant flow rates.

The Model HP-40-02 Coolant Centrifuge has two rotor's with swivel elbow's for each rotor inlet for the dirty coolant entry. The speed of each direct drive motor is 3420 RPM for a sustained G-force of 1600. This allows the centrifuge to be used for applications such as EDM that are normally considered to be out of reach for a low speed centrifuge. Flow rate is 35-40 GPM (132-151 LPM) with water. Refer to "specifications" for coolant flow rates.

### Principle of Operation

The Series 20 Coolant Centrifuge has a single rotor and one inlet, the Series 40 has two rotors and two inlets. Please note that all information given in the following paragraphs will apply to both coolant centrifuge (except where shown). Reference to rotors etc. for Series 20 must be interpreted in the singular sense. Similarly, the same information when applicable to Series 40 Centrifuge must be interpreted in the plural sense.

The dirty coolant is fed into the centrifuge by means of the inlet pipe. It then passes into the open topped rotor which is driven round at high speed. The coolant is then directed by the center cone to the bottom where centrifugal force causes the particles in the coolant to pack against the wall of the rotor liner.

Clean coolant is forced past the vane assembly, out of the rotor, and flows into the storage or holding tank. Units having an integral tank are fitted with a return clean pump. Cleaned coolant is pumped back to the machine or to its auxiliary coolant tank. It is important to ensure the output of the pump does not exceed the input. Check the capacities on the instruction plate.

All rotors are fitted with a removable liner shaped to the inner contours of the rotor. A removable vane assembly secures the liner in the rotor. This consists of an open top ring and a number of vertical paddle type vanes.

### Typical Arrangement

The basic centrifuge does not have the ability to store the cleaned liquid and there must be some method to get the dirty liquid to the centrifuge. This is most commonly done by mounting the centrifuge above a tank. The tank should be divided into a dirty section, where the dirty liquid from the machine tool is directed. A dirty feed pump is located in this tank to pump the dirty liquid into the centrifuge swivel elbow. A variation of this would be a gravity line or existing pump line into the inlet elbow, eliminating the need for the dirty tank and dirty feed pump.

The centrifuge is located above the clean side of the tank so that the cleaned liquid flowing out of the centrifuge drops into the clean tank. A clean pump located in this tank pumps the cleaned liquid back to the machine tool. There should be an overflow from clean to dirty so that the system will stay in balance.

### Portable Units

The HP-20 unit can be made in a portable configuration. Typically these include a self priming feed pump to feed dirty fluid to the centrifuge, and either a gravity discharge set up for the clarified fluid or a discharge pump arrangement is used. These units come on a base with casters and include dirty feed and clean discharge hoses.



# Installation

## Responsible Persons

Responsible persons who are responsible for the processes involved in the design, selection and erection of explosion protected equipment shall possess, at least, the following:

- General understanding of relevant electrical engineering
- Understanding and ability to read and assess engineering drawings
- Working knowledge and understanding of relevant standards
- Basic knowledge of quality assurance, including the principles of auditing, documentation, traceability of measurement and instrument calibration

Such persons shall confine their involvement to the management of competent operatives conducting selection and erection duties and not engage themselves directly in the work without ensuring their practical skills at least meet the requirements given in below.

## Operatives (Selection and Erection)

Operatives shall possess, to the extent necessary to perform their tasks, the following:

- Understanding of the general principles of types of protection and marking
- Understanding of those aspects of equipment design which affect the protection concept
- Understanding of content of certificates and relevant parts of this standard
- General understanding of inspection and maintenance requirements of EN 2006/42/EC
- Familiarity with the particular techniques to be employed in the selection and erection of equipment referred to in this standard
- Understanding of the additional importance of permit to work systems and safe isolation in relation to explosion protection.

## Transport and Handling

The courier is always liable for any damage during transit to the goods that have been entrusted to the same. Before preparing the unit for installation and commissioning, a thorough visual inspection must therefore be carried out to check that the packaging is intact and that the unit presents neither visible damage. Also, ensure that the units correspond to the order that was placed by customer.

Any damage or complaints should be reported to Eriez and to the carrier by recorded delivery letter within 8 days from receiving the goods.

Should one or more components be damaged, do not proceed with starting up the unit and inform Eriez of the problem, agreeing with the latter the actions to be taken.

Preferably remove the packaging at the actual place of installation.

Internal handling must be carried out with the utmost care, without using unit components as handholds. To avoid damage it is essential when moving the units that they always remain in the position envisaged for their operation.

Do not leave packaged units in places exposed to strong sunlight, since the internal temperature could reach safety device tripping values.

Lifting should preferably be carried out with a lift truck. Use a spreader beam if belts or ropes are used for slinging, making sure that there is no pressure on the upper edges of the units or the packaging.

### Example of Lifting with a Lift Truck

Insert protection for the outer structure of the unit, for example a sheet of cardboard or polystyrene.

Make sure that the forks of the lift truck project at least 100 mm from the other side of the unit.

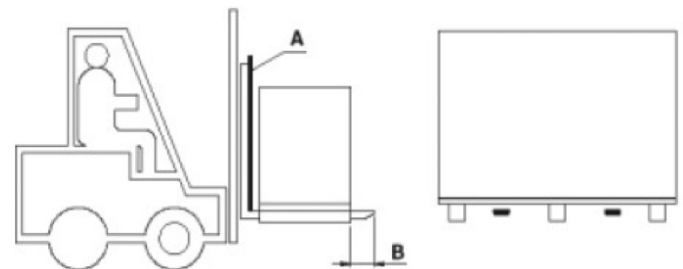

### Example of Lifting with Ropes

1. Place the lifting pipes like the figure.
2. Place rigid structures on the upper edges of the unit so as to ensure it is not damaged (only in the case of one point at which the force acts).



3. Tighten the hoisting straps gradually, ensuring that they are correctly positioned.
4. Begin hoisting the unit.

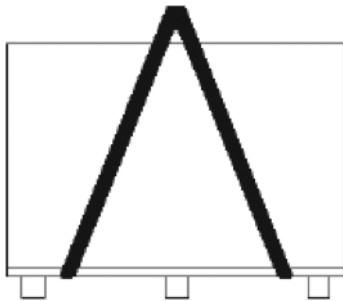

## Handling

It is important to handle this equipment carefully to avoid twisting or bending the trays. Ensure the lifting lugs provided are used when lifting or moving the equipment. The equipment can be moved into place with the aid of a fork lift truck.

## Wiring

Wiring to the motors should enter from a flexible conduit. Use of a motor starter and circuit protection is situated in the main control cubicle. Interconnector wiring must be properly sized to prevent line voltage drop and excessive heating of the cables.

## Positioning

The filter should be sited alongside the machine tool so as to allow the coolant to be gravity fed into the inlet trough via a chute, pumped or piped in. (customer responsibility to provide dirty coolant to the filter).

## Electrical Installation

The unit should be connected to a 3-phase electrical supply, incorporating a suitably sized 3-phase interlocked circuit breaker. Refer to circuit diagram for connection details.

## Leveling

Leveling the centrifuge can be carried out with reasonable accuracy using an engineer's level. Open the lid of the centrifuge and place the level on the rotor and adjust the leveling bolts at the bottom of the unit. Turn the level through 90° and re-check levels.

## Pumps

The pumps on all centrifuges should be wired to the control panel interlock of the machine tool and not from the centrifuge control. This allows the rotor to run continually until cleaning is necessary, even though the coolant flow is interrupted when changing the work piece.

## Cycling and Batching

General - The centrifuge may be allowed to operate without liquid from the host machine tool for an indefinite time. This is beneficial because:

- Frequent starting and stopping is likely to cause "nuisance tripping" and reduce motor life.
- The centrifuge rotor bowl liner must be cleaned at each start-up.
- Running just the dirty feed pump and centrifuge, without the clean pump, allows all the dirty liquid to make continued passes through the rotor bowl for continued filtration.

## Mechanical Installation for Units Without an Integral Tank

Bolt the clarifier to an outlet manifold storage or holding tank, which must be provided with an overflow. This is to prevent flooding of the rotor. For transit purposes, the gasket used for the "letter box" opening will be found inside the unit. This must be taken out and fitted onto the outside of the unit to connect the manifold, holding or storage tank.

### Pipe Connection

When connecting the dirty coolant for a gravity feed application, allow a fall of 2" (51mm) minimum of piping, this is to ensure a steady flow of coolant. The dirty coolant line is connected to the inlet pipe on the clarifier lid. Position the dirty coolant line so that the lid can be opened without having to disconnect the pipe. The clarifier requires 2" (51mm) bore flexible tubing (plastic tubing reinforced with canvas or equivalent is recommended) for the inlet pipe, which must be secured with a suitable hose clip.

### Ensure That There are No Restrictions

When the system is fed using a transfer pump then a 1-1/4" (32mm) inlet should be fitted.

### Feed Plumbing Supplied With Stand Alone Units

Units sold without tanks include a section of 1-1/4" (32mm) hose, hose barbs, and a pipe union with an orifice hold drilled to set the flow rate to not allow over feeding the centrifuge installed on the centrifuge dirty inlet. The hole is set so flow should not be more than 15 GPM (57 LPM) on water per rotor. If the flow required is higher contact Eriez to calculate the orifice size based on feed pump pressure.

## Mechanical Installation of Units With Tanks

Place the centrifuge near the coolant outlet of the machine. Then connect the dirty coolant line from the machine to the inlet-pipe positioned on the lid of the centrifuge.

On Series 40 Centrifuge there are two inlet elbows; it is important that the flow of coolant be equally divided between the two. To achieve this, the pipe junction must be near the machine tool and each pipe as near equal length as possible. The outlet of the return pump is adjacent to the pump motor. The piping from this to the work area of the machine should be made by means of suitable pipe work. It is important that there are no pipe restrictions.

## Flows and Balancing

### **The dirty feed pump flow rate must be restricted:**

Too much flow into the centrifuge will reduce the time the liquid is allowed to stay in the rotor bowl, so particles of swarf will carry over into the clean storage tank, giving reduced filtration. Excessive flow rates can also cause flooding of the unit, resulting in bearing failure and/or motor overloading. Slow flow rates will improve the degree of filtration.

### **The clean pump flow rate must be restricted:**

The clean pump discharge valve must be throttled until there is an overflow of clean liquid from the clean tank to the dirty tank. If the clean pump is allowed to pump faster than the lift pump, then the system will be “out of balance” as indicated by liquid collecting in the dirty tank.

Units supplied with a feed pump will have a feed orifice plate installed to set the flow rate.

## Set Up of Portable Units

Any pump, feed or discharge, must be primed the first time they are used and any time the system has been completely drained of all fluids. A tee pipe fitting with a pipe plug is installed on the pump discharge line. Remove the pipe plug and pour the fluid that will be centrifuged into the pump head until it is full. Replace the pipe plug, use pipe thread sealing compound or tape to insure a leak free installation.

Dirty feed and clean discharge hoses must be placed into the fluid tank that will be processed. Place the dirty feed hose well into the liquid of the tank. If the unit is set up for gravity discharge of the clarified fluid, make sure the discharge hose does not go up in the air, it must have a gentle down slope to it, and make sure the

end of the hose does not get submerged in the fluid. Failure to do either will cause fluid to back up into the centrifuge cabinet and can cause drive failure.

Portable units supplied with a feed pump will have a feed orifice plate installed to set the flow rate.

## Commissioning

1. Remove all external packaging.
2. Open the lid with power on to check vane and liner securely in place and no items remain. Must hold the red stop button to open lid. Lid cannot open if power is not connected or isolator is not in correct position or rotors spinning.

---

### DANGER

**Under no circumstances should the bowl or liner be touched or handled while the bowl is rotating.**

---

3. Stand alone units will be shipped with the lid lock latch loose. Lift the lid and attach the latch with the supplied 2 screws. If power is not available use the screw key (located inside the terminal box – accessed by removing cover panel and front of terminal box)). The screw key used on the end of a socket screw driver is used to release a screw located on the Lidlock, fitted above the terminal box.
4. With liner and vane assembly correctly in place, fill the liner to half full of liquid to be processed.
5. Close lid, check all hoses and connections before starting.
6. The centrifuge is now ready for use.



# Operation

**!** If the centrifuge is started without cleaning the sludge from the rotor bowl liner, even if it is only partially full, the unit could run out of balance and become damaged through excessive vibration. Make sure the rotor has been cleaned and properly assembled before running.

## Start Up

**A DIRTY FEED PUMP SHOULD NOT BE STARTED, NOR A DIRTY FEED VALVE OPENED, AT THE SAME TIME AS THE CENTRIFUGE IS STARTED.**

The lid must be closed in order to start the system. The centrifuge is started by the use of a "Centrifuge Start" push button on the unit. The GREEN LED light "Filter Running" will light showing the rotor is running.



After about 20 seconds, the centrifuge gets up to speed and will be able to filter (the centrifuge will not start if the lid is open). Once the centrifuge has been started, start the customer supplied dirty fluid feed pump, or the feed pump supplied on a tank system, to feed fluid to the centrifuge 30-45 seconds after the centrifuge is started.

## Shut Down

**Stop the feed pump or close the feed valve before stopping the centrifuge.**

Stop the centrifuge 30-45 seconds after stopping the feed pump or the feed valve has been closed.

The centrifuge is stopped by pressing the RED "Centrifuge Stop" push button on the unit. An electronic brake module will bring the rotor to a complete stop.

The electronic break system includes the contractors for running 3-phase, motor, a rotation sensing circuit, a DC injection brake, and an over temperature protection circuit, as well as various output signals.

The unit is factory set and should not be adjusted without consent from Eriez Aftermarket Service Dept.

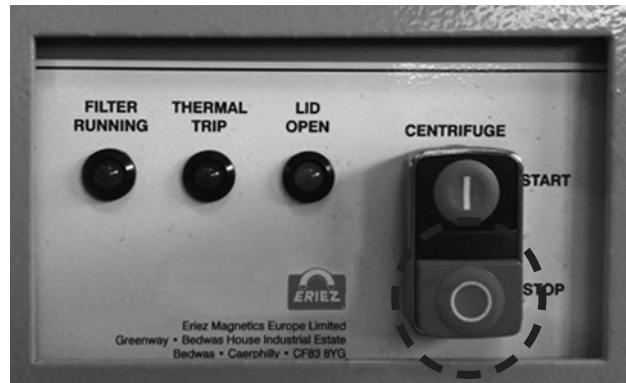

Pressing the RED stop button will bring in the DC injection brake, which will be applied at intervals until the rotation sensing circuit is sure the rotor bowl has stopped turning. There is a lid module with release solenoid inside the centrifuge cabinet, operated by the rotor brake module, so the lid release solenoid will not release the lid until the rotor is completely stopped. The YELLOW LED light "Lid Open" will light when the rotor is stopped. At this time press the RED stop button while lifting the lid.

A lid lock prevents the lid from being opened during running of the centrifuge. The lid is held in the closed position by a spring loaded plunger. A solenoid retracts the plunger when the motor rotor has stopped rotating and a timer times out.

### **!** DANGER

**Under no circumstances should the bowl or liner be touched or handled while the bowl is rotating.**

### **!** DANGER

**Failure to allow the bowl to stop before handling may result in serious personal injury.**

# Maintenance

---

## WARNING

Before carrying out any maintenance on the Filter refer to Health and Safety, and Risk and Hazard Assessment, in this manual. All maintenance personnel must be suitably trained and passed as competent. All personnel should be made aware of the location and operation of the Emergency Stop button.

## WARNING

Before carrying out any maintenance ensure that the Filter is rendered safe, with services switched off and isolated, prior to commencing maintenance tasks.

---

## General Safety Rule

Before carrying out inspections, maintenance and controls, scrupulously comply with all that is listed below:

- Check that the power on/off switch is off. Lockout/tagout procedure is done per company guidelines
- Check that there are no moving parts supplied from auxiliary supplies
- Check for potential hazards from other equipment's being started
- Observe the accident-prevention regulations.
- Put on adequate personal protective equipment (gloves, goggles, etc.).
- Except for visual inspections, all the operations are to be carried out solely by specialized and expert personnel; otherwise the warranty is rendered invalid.

---

## DANGER

Under no circumstances should the bowl or liner be touched or handled while the bowl is rotating.

## DANGER

Failure to allow the bowl to stop before handling may result in serious personal injury.

---

## Rotor/Motor Maintenance

Centrifuge with 22" (560mm) inlet heights are fitted with TEFC (Totally Enclosed Fan Cooled) motors. These motors should not require attention for long periods. The bearing housing on which the rotor itself runs is fitted with a special type of grease pack bearing and requires no attention. Motor protection is incorporated in the form of thermistors which will operate if the motor is subjected to excessive overloading. If for some reason, it becomes necessary to remove the rotor motor, the following procedure should be adopted.

---

## DANGER

Under no circumstances should the bowl or liner be touched or handled while the bowl is rotating.

## DANGER

Failure to allow the bowl to stop before handling may result in serious personal injury.

---

1. Remove vane assembly and liner.
  2. Remove nose cone with spanner.
  3. Remove the two locknuts and lift rotor bowl from shaft.
  4. It will be seen that each motor is mounted on its own mounting plate, held in position by 18 bolts. These must be removed. NOTE: Reduce coolant level to below plate to prevent flooding.
  5. The complete motor assembly can now be lifted out using the lifting handles provided on the mounting plate, ensuring that any surplus coolant is wiped from around the mounting plate.
  6. The electrical wires to the motor must now be disconnected, either from the motor terminal box or from the terminal strip in the electrical control box.
  7. While the unit is disassembled, check the following for wear: Set of three anti-vibration mounts V-ring seal (small boot) Sealing cap (large boot)
- 

 After a short period of operation (1 - 2 weeks) the bolts on the plate and cylinder may become loose. The 16 bolts will need to be checked and hand tightened to prevent leaks.

## WARNING

The V-ring seal and sealing cap must be replaced in the proper position and properly seated or liquid will pass the two seals and short out the drive motor! Refer to the parts diagram at the end of this manual when reassembling.

---



## Cleaning Rotor Liners

The frequency of cleaning will depend on the rate of solids removed. The liners should be emptied when it is found that the spaces between the vanes are filled with solid material, initially a daily or hourly inspection should be made to establish the frequency of cleaning.

---

### **⚠ DANGER**

**Under no circumstances should the bowl or liner be touched or handled while the bowl is rotating.**

### **⚠ DANGER**

**Failure to allow the bowl to stop before handling may result in serious personal injury.**

---

1. First release latches with the key provided. Then, to release latches, turn them through 90° in an anti-clockwise direction.
2. Remove the vane assembly by hand; some materials tend to stick to the vanes.
3. Using the moulded rubber handles, lift the filled liner from the rotor.
4. Clean and replace the liner. When replacing the rubber liner, it is important to position the handles at right angles to the vane-registering slot in the rotor. This allows the vane assembly to be inserted without fouling the handles of the liner.
5. The vane assembly can now be cleaned and replaced; it should be noted that the vane assembly has a registered tongue, which is important for locating purposes. It is advised that the vane assembly from one rotor should not be fitted to any other rotor, either in the same clarifier or in another clarifier; as this could destroy the original balancing.
6. Lock all latches with the key provided.
7. Fill liner halfway with coolant.



---

### **⚠ WARNING**

**Do not empty dirty coolant from the liner into the clean coolant in the storage or holding tank.**

---

8. Finally, close lid and restart (see start up procedure on page 11).

## Operation and Application Information

### **Wear Pattern of The Centrifuge and Components**

Although the centrifuge has been upgraded over the years it is still susceptible to wear or damage from overuse or abuse. Observing the following can minimize failure of the centrifuge and wear:

**Flow Rate** Do not feed more than the design maximum of 18-20 GPM (68-76 LPM) water for HP20 units and 35-40 GPM (132-151 LPM) water for HP40 units. An overflow condition will, in time, allow liquid to work past the V-ring seal, sealing cap, and finally into the bearings.

**Solids Build Up** After the initial startup, stop and check the rotor bowl liner for solids content. Operating the centrifuge with a full rotor bowl liner will prevent any filtration, as there is no space left to fit any solids. The weight of the full rotor bowl will only add wear to the components.

**Pre-Start Up** Before starting the centrifuge, check to be sure it does not contain any solids. Solids in the rotor bowl liner may break up and lodge against the wall of the inner on one side, causing an imbalance. Avoid frequent starting and stopping, as this will add heat and strain to all electrical components, also the drive belt.

**Gas Spring** Closing of the centrifuge lid is cushioned by the gas springs located on the side of the cabinet. The springs should be replaced if they lose resistance.

### **Over Temperature Protection**

The electronic brake includes a circuit, which senses the temperature of the motor, utilizing the thermistors in the motor windings. In the event of the motor becoming too hot, the unit will switch itself off. It will not be possible to restart the unit until it has cooled down when the circuit will automatically reset.

### **Operational Outputs**

Signals can be provided, if specified, to indicate power on, motor running and over temperature trip. A signal is also available which will start a pump only when the centrifuge is at its full running speed.

## Equipment to Meet Special Requirements

### Temperature Control

Coolant temperature fluctuation is followed by work piece size fluctuation; therefore effective control of the temperature of the clarifier coolant may be necessary. Air blast cooler or refrigerated cooler could achieve this. Coolant clarifiers can be fitted with an integral temperature or control to ambient within specified limits if required.

### Pressure Coolant

When grinding wheels rotate at high speed, an air barrier is created through which coolant cannot normally penetrate but the coolant can be taken right to the point of cutting if the clarifier is fitted with pressurization equipment.

### Anti-Misting

Some coolants, such as paraffin based honing fluids, give off potentially dangerous fumes when disturbed. Coolant clarifiers can be fitted with a simple condenser to overcome this. This condenser is fitted into the clarifier and consists of a small box unit. Inside are fitted a series of baffle plates, or special filter elements, on which the paraffin fumes condense. Air is allowed to leave the clarifier through the condenser and the condensed liquid drops back into the clarifier.

## Optional Extras

A number of optional extras can be supplied for use with Series 20 and 40 Centrifugal Clarifiers.

Clarifiers can be supplied with an inverted cone vane assembly for low throughputs or controlling difficult sludge separation.

Heating coils can be fitted into clarifiers with integral tanks.

Pre-rough filtration can be supplied prior to the centrifuge to reduce the frequency of emptying the rotor liners.

## Spare Parts

Detail No.	Part No.	Description	No. Off
1	F.30.22320	Latch Plate Vane Assembly	1
2	F.50.03000	Rotor Liner	1
3	F.52.01030	Nose Cone	1
4	226198	Locknut	2
5	458845	Rotor Washer	1
6	5.30.28000	Latch Ring	1
7	F.62.02220	Rotor Bowl Small Bore	1
8	468308	Sealing Cap	1
9	468309	'V' Ring Seal	1
10	F.62.02070	Stainless Steel Spacer	1
11	471352	Rotor Screen Seal	1
12	472763	Rotor Screen Assembly	1
13	471856	Plate & Cylinder Assembly	1
14	460476	Plate & Cylinder Gasket	1
15	F.24.02030	Circlip	1
16	468305	Rotor Cover Plate	1
17	472784	Lid lock actuator	1
18	F.52.00000	Inlet fitting gasket	1
19	471958	Gas Spring	1
20	467807	Anti-Vibration mount separately sold. Need 3 total	3
21	F.43.01540	Drive Motor	1
22	F.62.03060	Latch Key	1
23	464855	Brakeboard Issue 3 49002005	1



# Troubleshooting

<b>Problem</b>	<b>Possible Cause</b>	<b>Solution</b>
<b>Centrifuge will not start</b>	Mains supply is not on	Switch on mains supply
	Thermistors cut out	Wait for resetting
	Motor failure	Fit new motor
	Contactors faulty	Clean contacts
	Control coils burnt out	Fit new control coils
	Fuse(s)	Fit new fuse(s)
	Lit interlock micro-switch out of adjustment	Adjust micro-switch
<b>Thermistor cut-out</b>	Coolant overflow hole blocked up	Clear overflow hole
	Skirt full of coolant	Remove rotor & clean out coolant
	Excessive braking	Too many stops
	Excessive coolant flow	Reduce flow from pump
<b>Lid cannot be opened</b>	Mains supply not on	Switch on mains supply
	Electronic PCB faulty	Change PCB
	Lid interlock assembly faulty	Fit new assembly
<b>Clarifier motor</b>	Loose or broken supply wire	Tighten connections
	Insulation breakdown	Fit new clarifier motor
	Bearing failure	Fit new bearings
<b>Reduced coolant flow</b>	Coolant pump motor running in reverse direction	Change over any two pump motor power wires so that the pump operates in the correct direction
<b>Excessive Vibration</b>	Occasionally, if a rotor is left standing for a long period, part of the cake may fall into the center of the liner, thus causing an "out of balance" condition when the rotor is next used	Remove liner and clean out cake
	Dirty liner fitted	Remove liner and clean all over
	Clarifier not level	Level clarifier as detailed in the operating instructions
	May be due to a latch on the rotor being not completely secured	Secure latch with tool provided
	Coolant pump out of balance	Change pump



# Outline HP20 Centrifuge

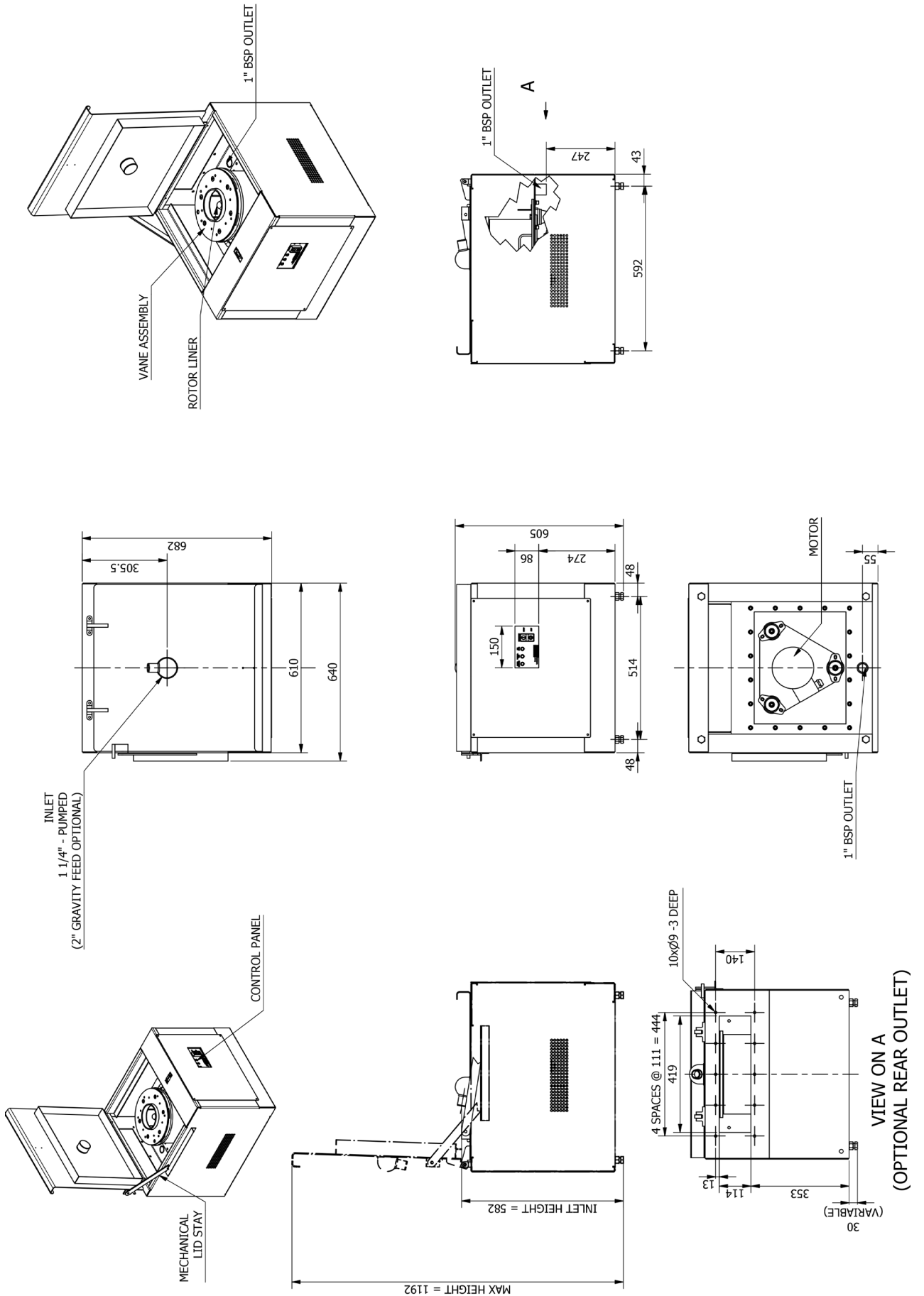



# Outline HP40 Centrifuge

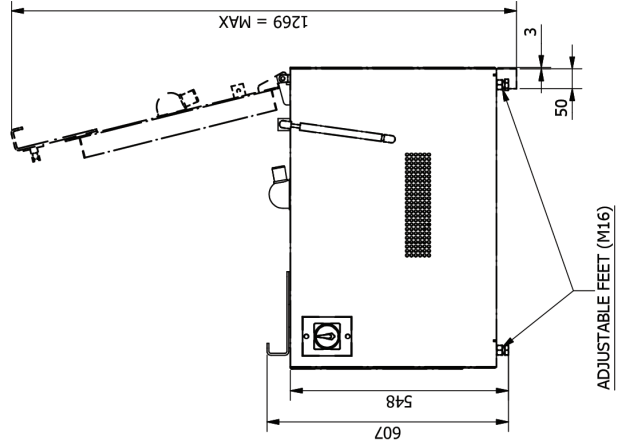
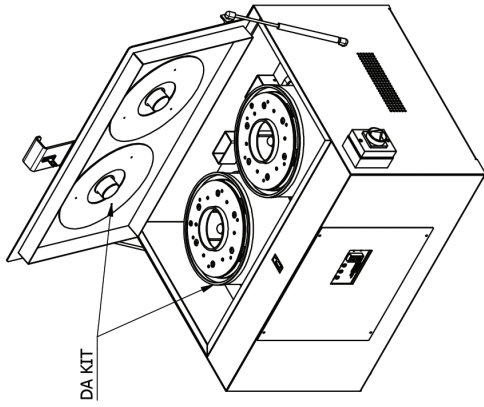
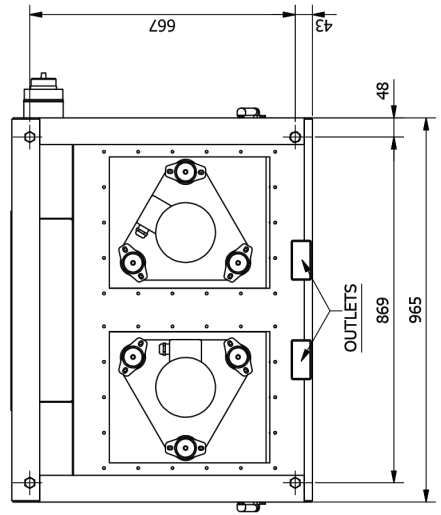
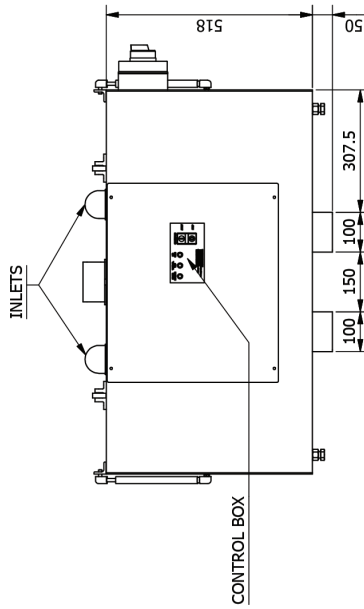
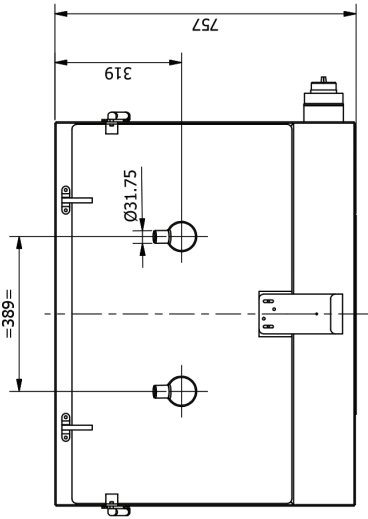



# Electrical Schematic: HP20 Single Centrifuge

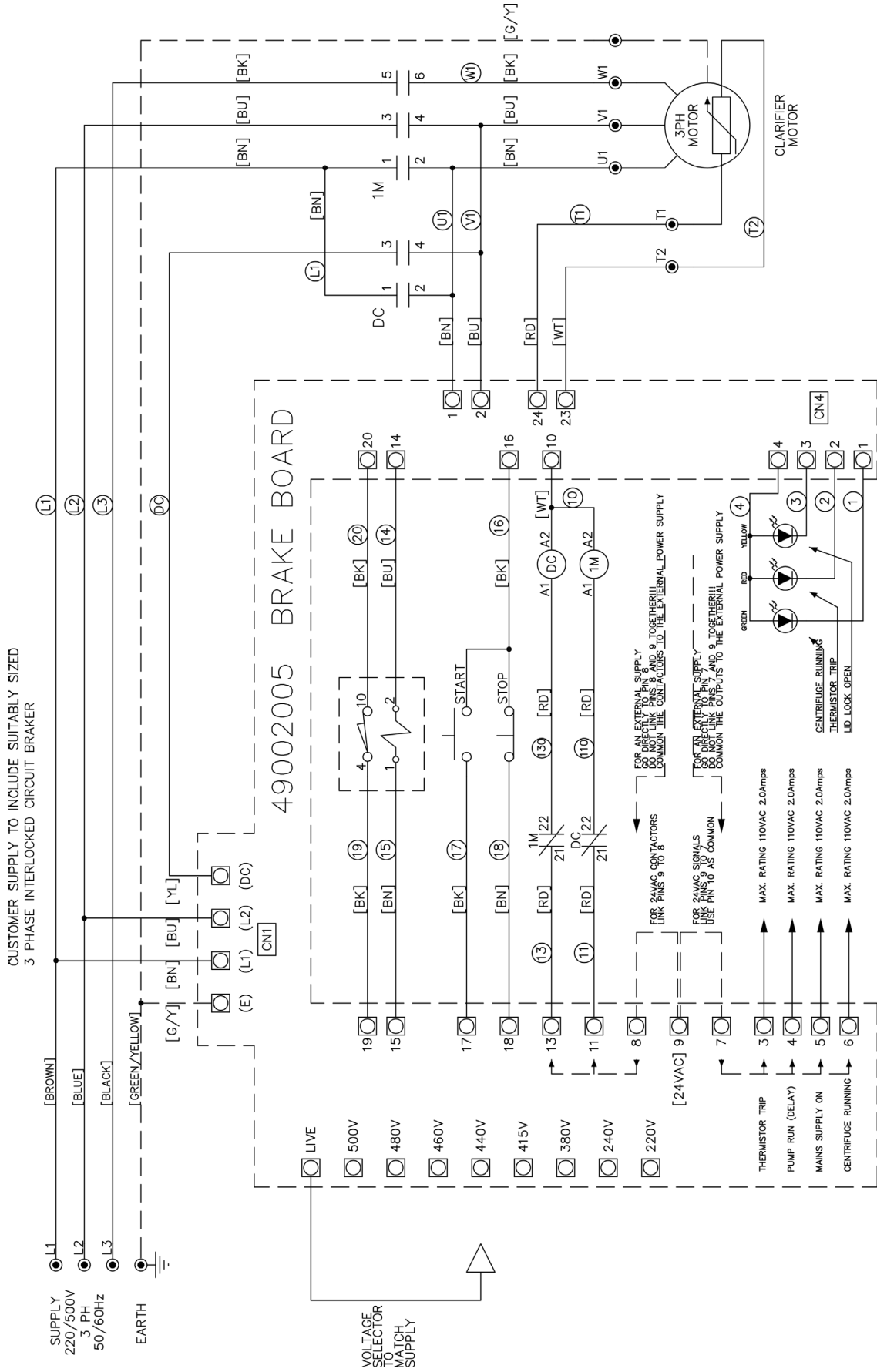

# Electrical Schematic: HP40 Double Centrifuge

CUSTOMER SUPPLY TO INCLUDE SUITABLY SIZED  
3 PHASE INTERLOCKED CIRCUIT BREAKER  
STARTING CURRENTS CAN EXCEED 20 AMPS FOR 5 SECONDS PER CENTRIFUGE MOTOR.  
ALLOW 15 SECONDS AT 20 AMPS FOR DOUBLE CENTRIFUGES.

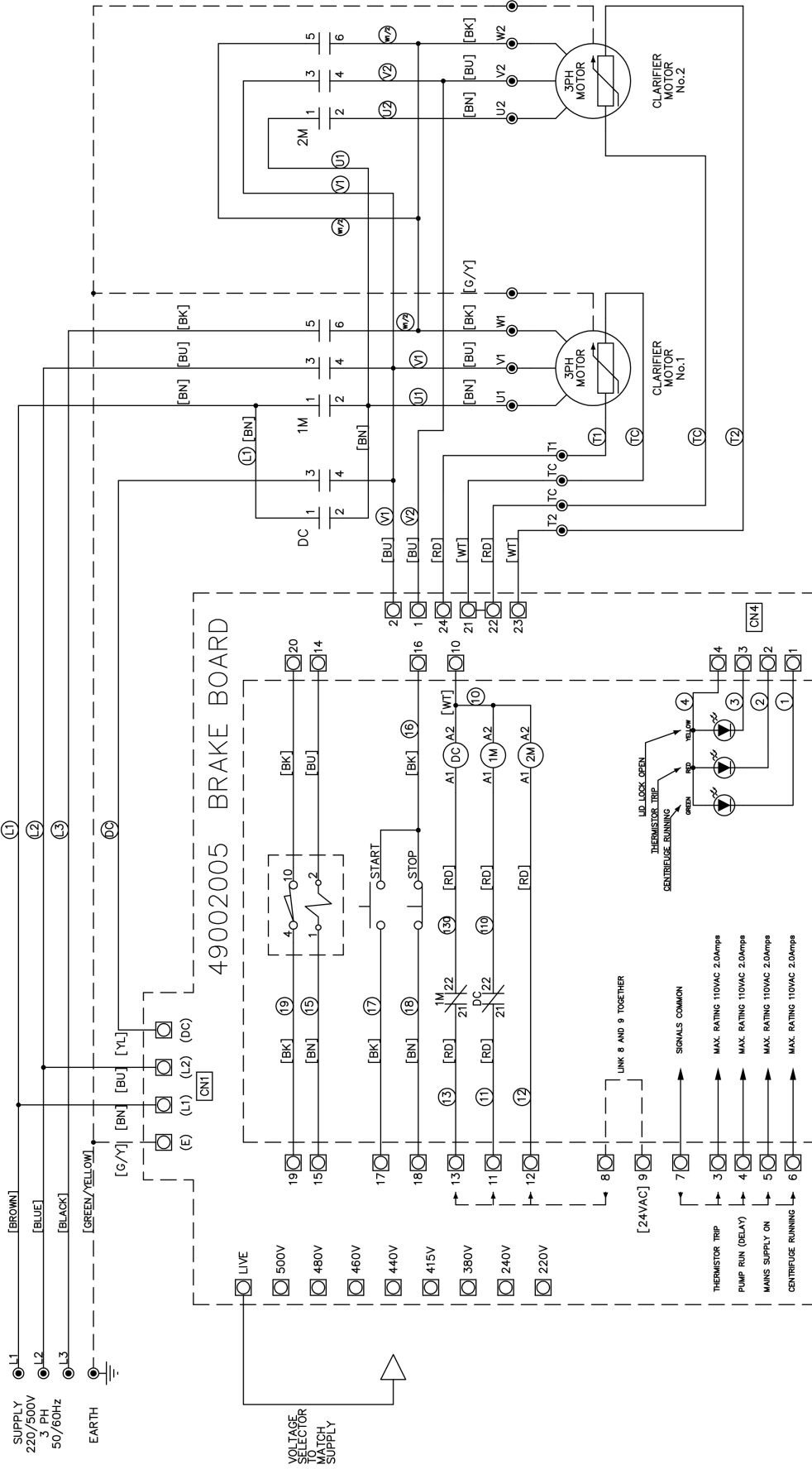

2-49002005 Brakeboard Eriez part # 464855



# HP20 Centrifuge Square Parts

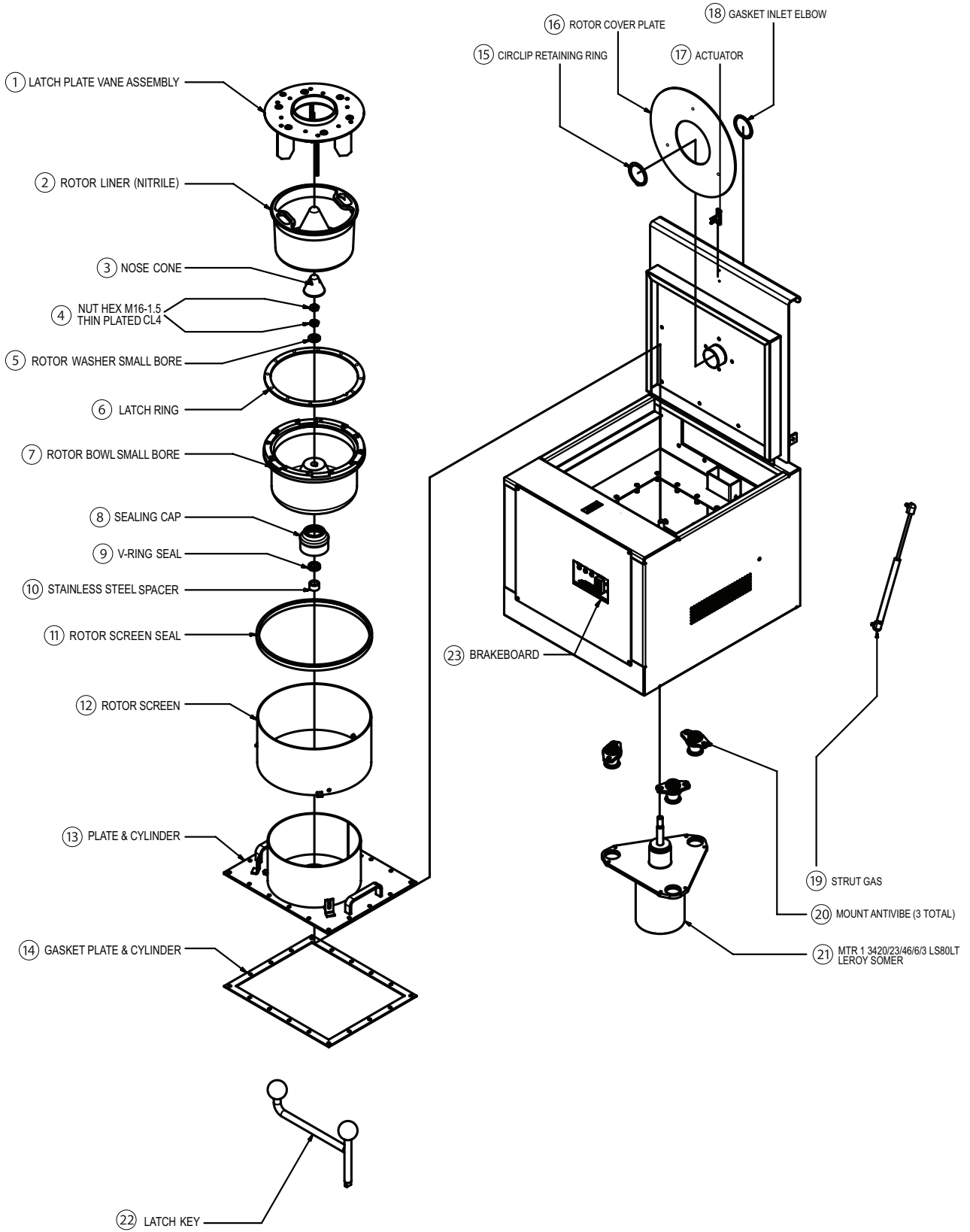

# HP40 Centrifuge Square Parts

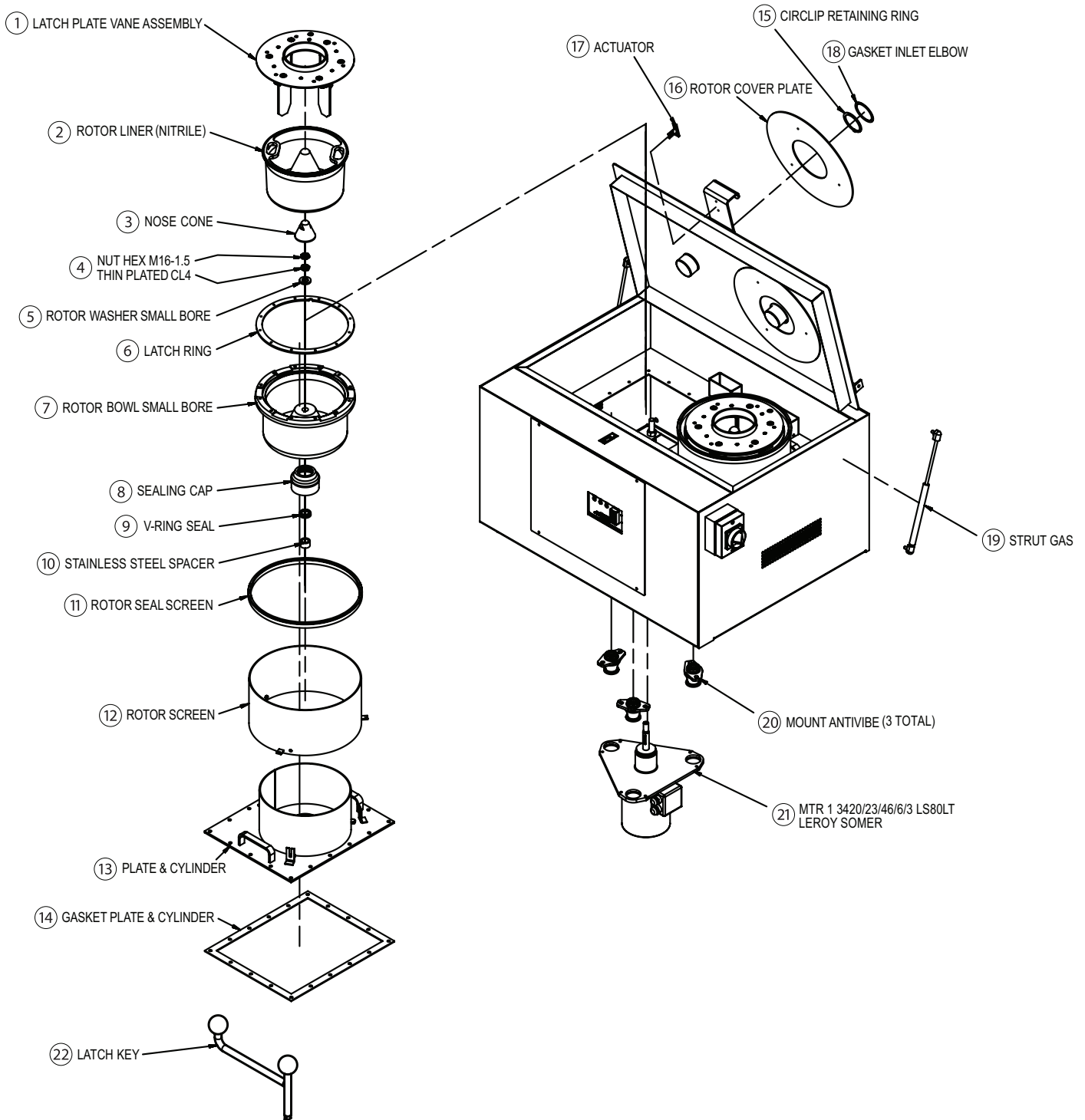



# Centrifuge Electric Disconnect

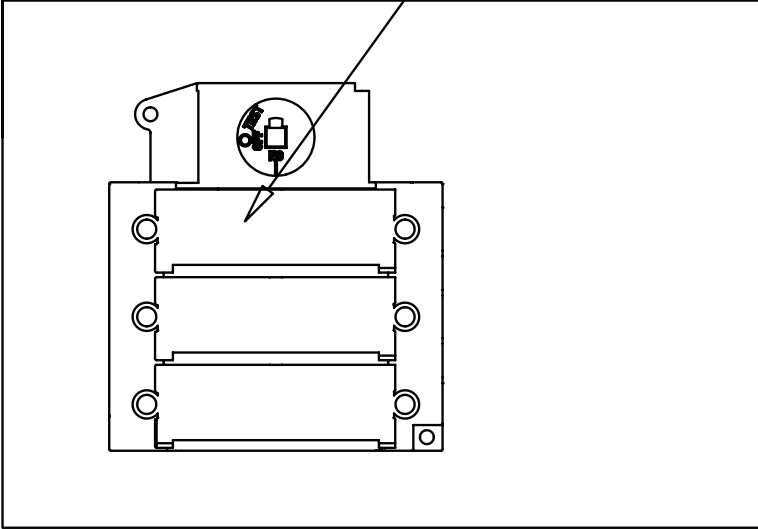
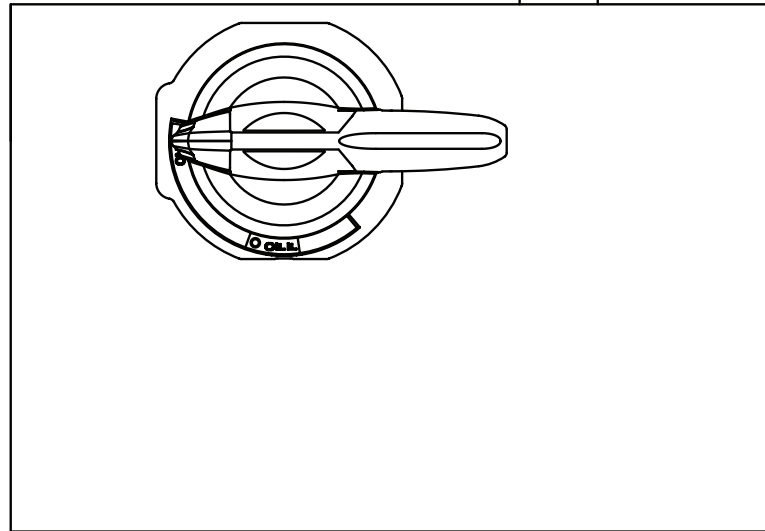

NOTE:  
PARTS ARE FOR REFERENCE ONLY. UNIT COMES  
FULLY ASSEMBLED FROM VENDOR.

VENDOR TO LABEL BACK PANEL WITH FUSE  
INSTALLED.

# HP20 Stand Alone Centrifuge With Inlet Plumbing

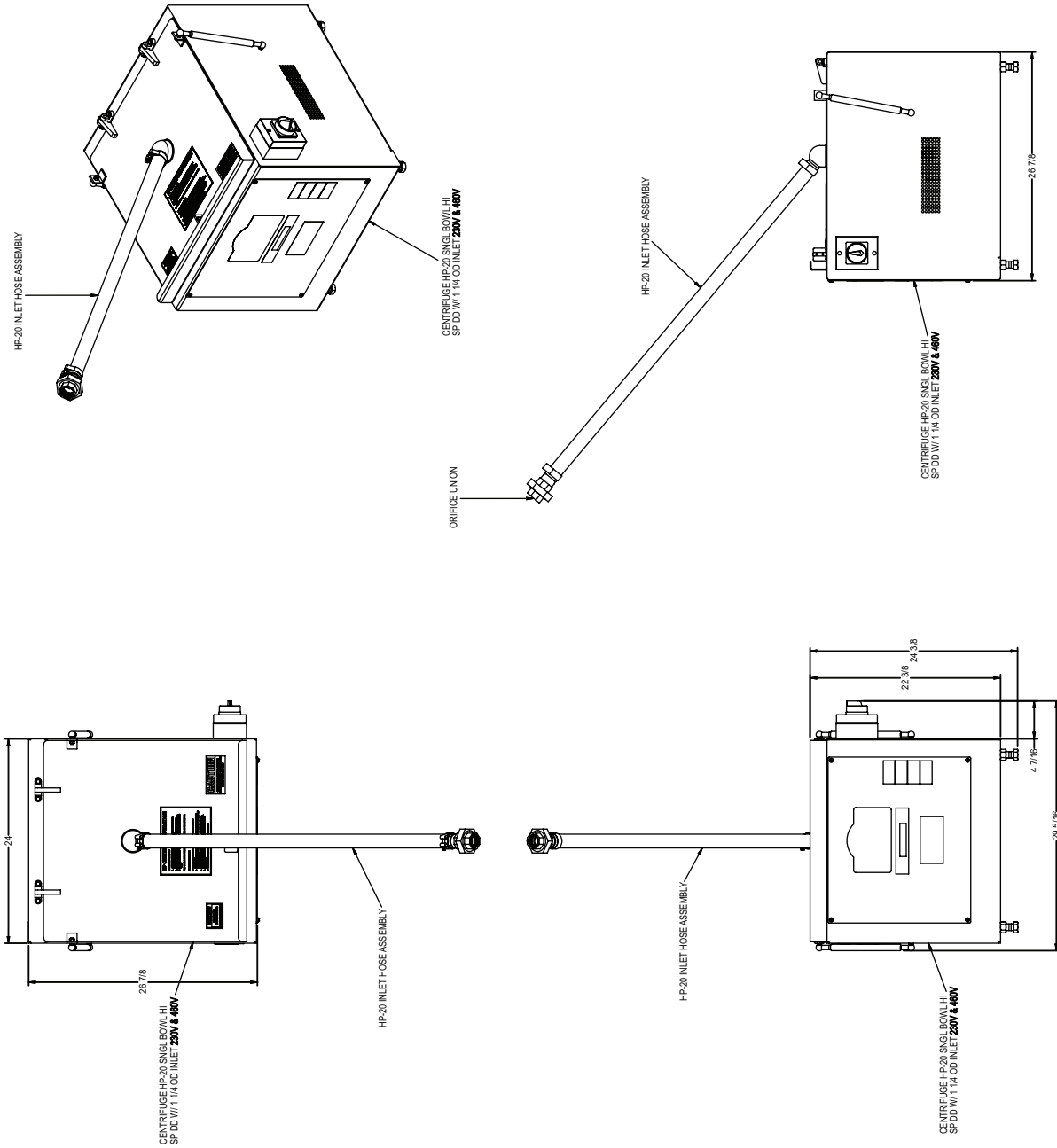



# HP40 Stand Alone Centrifuge With Inlet Plumbing

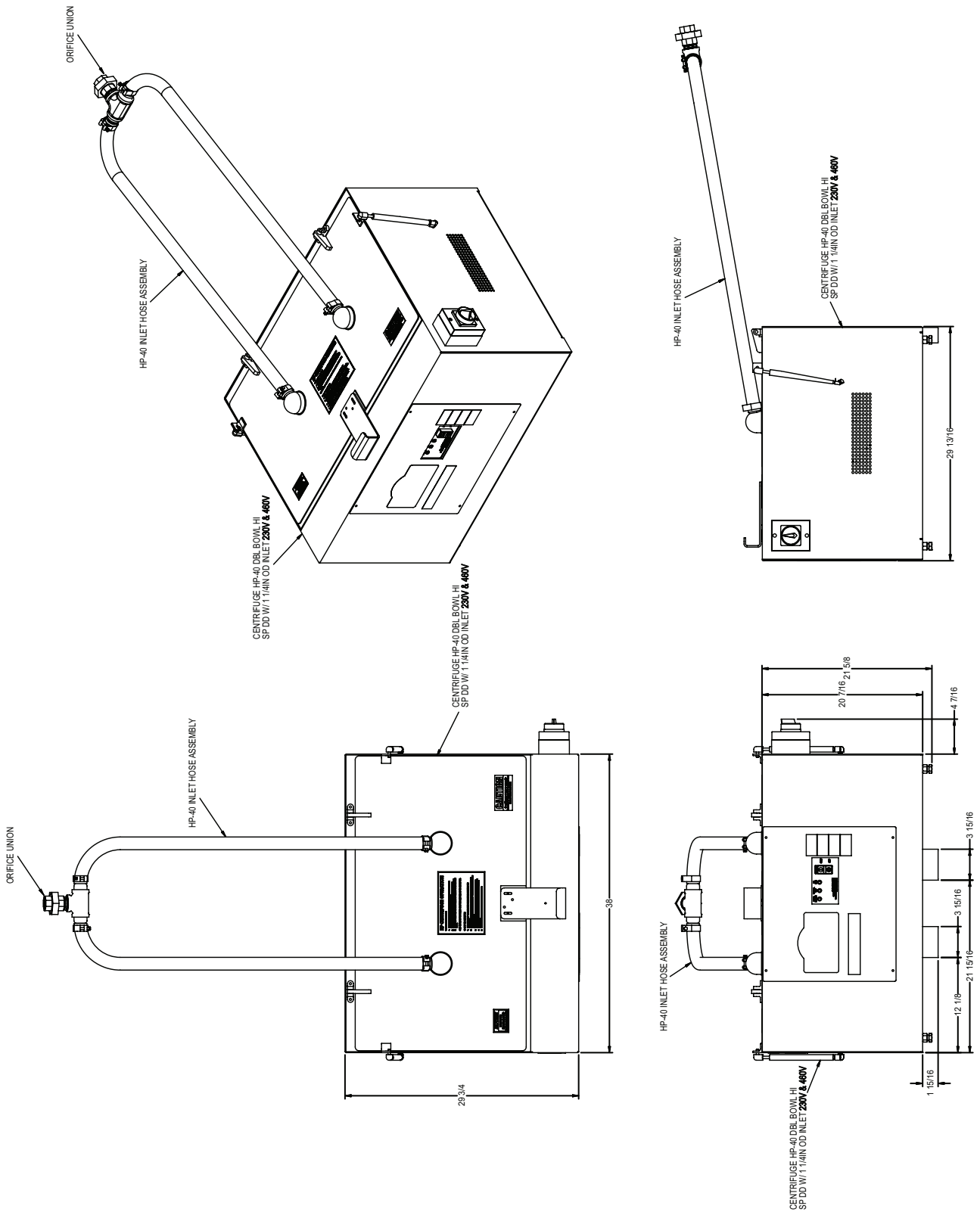



# HP CENTRIFUGE OPERATION

## TO START THE CENTRIFUGE

1. MAKE SURE THE ROTOR LINER HAS BEEN CLEANED AND THE ROTOR ASSEMBLED CORRECTLY. LID MUST BE CLOSED.
2. FILL BOWL LINER HALFWAY WITH WATER TO STABILIZE BOWL ON STARTUP
3. START THE CENTRIFUGE BY PRESSING THE GREEN START BUTTON.
4. WAIT 30-45 SECONDS TO ALLOW CENTRIFUGE TO COME TO FULL SPEED.
5. TURN DIRTY FEED PUMP ON OR IF FEEDING BY GRAVITY OPEN THE FEED VALVE.

PUMP SHOULD NOT BE TURNED ON AT THE SAME TIME AS THE CENTRIFUGE.

## TO STOP THE CENTRIFUGE

6. STOP FEED PUMP OR CLOSE FEED VALVE BEFORE STOPPING THE CENTRIFUGE
7. STOP CENTRIFUGE 30-45 SECONDS AFTER STOPPING THE FEED PUMP OR THE FEED VALVE HAS BEEN CLOSED. TO STOP THE CENTRIFUGE PRESS THE RED STOP BUTTON.
8. WHEN THE ROTOR IS STOPPED THE YELLOW LED LID OPEN LIGHT WILL COME ON. PRESS THE RED STOP BUTTON WHILE LIFTING THE LID OPEN.
9. REMOVE THE ROTOR VANE ASSEMBLY AND REMOVE AND EMPTY THE ROTOR LINER.
10. INSTALL CLEAN LINER AND REINSTALL THE VANE ASSEMBLY.



### Global Leader in Separation Technologies

2200 Asbury Road, Erie, PA 16506-1402 U.S.A.

Telephone: 814-835-6000 • Fax: 814-838-4960

www.eriez.com e-mail: eriez@eriez.com

